

## **PARK CITY MUNICIPAL CORPORATION SERVICE PROVIDER/PROFESSIONAL SERVICES AGREEMENT**

This Service Provider/Professional Services Agreement (the “Agreement”) is made and entered into as of this 21<sup>st</sup> day of September, 2023, by and between **PARK CITY MUNICIPAL CORPORATION**, a Utah municipal corporation, (“City”), and **VISIBILITY SIGN COMPANY, LLC**, a Utah limited liability company, (“Service Provider”), collectively, the City and the Service Provider are referred to as (the “Parties”).”

WITNESSETH:

WHEREAS, the City desires to have certain services and tasks performed as set forth below requiring specialized skills and other supportive capabilities;

WHEREAS, sufficient City resources are not available to provide such services; and

WHEREAS, the Service Provider represents that the Service Provider is qualified and possesses sufficient skills and the necessary capabilities, including technical and professional expertise, where required, to perform the services and/or tasks set forth in this Agreement.

NOW, THEREFORE, in consideration of the terms, conditions, covenants, and performance contained herein, the Parties hereto agree as follows:

**1. SCOPE OF SERVICES.**

The Service Provider shall perform such services and accomplish such tasks, including the furnishing of all materials and equipment necessary for full performance thereof, as are identified and designated as Service Provider responsibilities throughout this Agreement and as set forth in the “Scope of Services” attached hereto as “**Exhibit A**” and incorporated herein (the “Project”). The total fee for the Project shall not exceed **\$47,800.00**.

The City has designated Jenny Diersen, Staff Liaison to the Park City Public Art Advisory Board, or their designee as City's Representative, who shall have authority to act on the City's behalf with respect to this Agreement consistent with the budget contract policy.

**2. TERM.**

No work shall occur prior to the issuance of a Notice to Proceed which cannot occur until execution of this Agreement, which execution date shall be commencement of the term and the term shall terminate on October 30, 2023, or earlier, unless extended by mutual written agreement of the Parties.

**3. COMPENSATION AND METHOD OF PAYMENT.**

- A. Payments for services provided hereunder shall be 50% at the time of execution of this contract and 50% after completion of the project.
- B. No payment shall be made for any service rendered by the Service Provider except for services identified and set forth in this Agreement.
- C. For all "extra" work the City requires, the City shall pay the Service Provider for work performed under this Agreement according to the schedule attached hereto as "**Exhibit B,**" or if none is attached, as subsequently agreed to by both Parties in writing.
- D. The Service Provider shall submit to the City Manager or his designee on forms approved by the City Manager, an invoice for services rendered during the pay period. The City shall make payment to the Service Provider within thirty (30) days thereafter. Requests for more rapid payment will be considered if a discount is offered for early payment. Interest shall accrue at a rate of six percent (6%) per annum for services remaining unpaid for sixty (60) days or more.
- E. The Service Provider reserves the right to suspend or terminate work and this Agreement if any unpaid account exceeds sixty (60) days.
- F. Service Provider acknowledges that the continuation of this Agreement after the end of the City's fiscal year is specifically subject to the City Council's approval of the annual budget.

**4. RECORDS AND INSPECTIONS.**

- A. The Service Provider shall maintain books, records, documents, statements, reports, data, information, and other material with respect to matters covered, directly or indirectly, by this Agreement, including (but not limited to) that which is necessary to sufficiently and properly reflect all direct and

## **PARK CITY MUNICIPAL CORPORATION SERVICE PROVIDER/PROFESSIONAL SERVICES AGREEMENT**

indirect costs related to the performance of this Agreement, and shall maintain such accounting procedures and practices as may be necessary to assure proper accounting of all funds paid pursuant to this Agreement.

- B. The Service Provider shall retain all such books, records, documents, statements, reports, data, information, and other material with respect to matters covered, directly or indirectly, by this Agreement for six (6) years after expiration of the Agreement.
- C. The Service Provider shall, at such times and in such form as the City may require, make available for examination by the City, its authorized representatives, the State Auditor, or other governmental officials authorized by law to monitor this Agreement, all such books, records, documents, statements, reports, data, information, and other material with respect to matters covered, directly or indirectly, by this Agreement. The Service Provider shall permit the City or its designated authorized representative to audit and inspect other data relating to all matters covered by this Agreement. The City may, at its discretion, conduct an audit at its expense, using its own or outside auditors, of the Service Provider's activities, which relate directly or indirectly to this Agreement.
- D. The City is subject to the requirements of the Government Records Access and Management Act, Chapter 2, Title 63G, Utah Code, 1953, as amended and Park City Municipal Code Title 5 ("GRAMA"). All materials submitted by Service Provider pursuant to this Agreement are subject to disclosure unless such materials are exempt from disclosure pursuant to GRAMA. The burden of claiming an exemption from disclosure rests solely with Service Provider. Any materials for which Service Provider claims a privilege from disclosure based on business confidentiality shall be submitted marked as "confidential - business confidentiality" and accompanied by a concise statement from Service Provider of reasons supporting its claim of business confidentiality. Generally, GRAMA only protects against the disclosure of trade secrets or commercial information that could reasonably be expected to result in unfair competitive injury. The City will make reasonable efforts to notify Service Provider of any requests made for disclosure of documents submitted under a claim of confidentiality. Service Provider specifically waives any claims against the City related to any disclosure of materials pursuant to GRAMA.

### **5. INDEPENDENT CONTRACTOR RELATIONSHIP.**

- A. The Parties intend that an independent Service Provider/City relationship will be created by this Agreement. No agent, employee, or representative of the Service Provider shall be deemed to be an employee, agent, or representative of the City for any purpose, and the employees of the Service

## **PARK CITY MUNICIPAL CORPORATION SERVICE PROVIDER/PROFESSIONAL SERVICES AGREEMENT**

Provider are not entitled to any of the benefits the City provides for its employees. The Service Provider will be solely and entirely responsible for its acts and for the acts of its agents, employees, subcontractors or representatives during the performance of this Agreement.

- B. In the performance of the services herein contemplated, the Service Provider is an independent contractor with the authority to control and direct the performance of the details of the work, however, the results of the work contemplated herein must meet the approval of the City and shall be subject to the City's general rights of inspection and review to secure the satisfactory completion thereof.

### **6. SERVICE PROVIDER EMPLOYEE/AGENTS.**

The City may at its sole discretion require the Service Provider to remove an employee(s), agent(s), or representative(s) from employment on this Project. The Service Provider may, however, employ that (those) individuals(s) on other non-City related projects.

### **7. HOLD HARMLESS INDEMNIFICATION.**

- A. The Service Provider shall indemnify and hold the City and its agents, employees, and officers, harmless from and shall process and defend at its own expense any and all claims, demands, suits, at law or equity, actions, penalties, losses, damages, or costs, of whatsoever kind or nature, brought against the City arising out of, in connection with, or incident to the execution of this Agreement and/or the Service Provider's negligent performance or failure to perform any aspect of this Agreement; provided, however, that if such claims are caused by or result from the concurrent negligence of the City, its agents, employees, and officers, this indemnity provision shall be valid and enforceable only to the extent of the negligence of the Service Provider; and provided further, that nothing herein shall require the Service Provider to hold harmless or defend the City, its agents, employees and/or officers from any claims arising from the sole negligence of the City, its agents, employees, and/or officers. The Service Provider expressly agrees that the indemnification provided herein constitutes the Service Provider's limited waiver of immunity as an employer under Utah Code Section 34A-2-105; provided, however, this waiver shall apply only to the extent an employee of Service Provider claims or recovers compensation from the City for a loss or injury that Service Provider would be obligated to indemnify the City for under this Agreement. This limited waiver has been mutually negotiated by the Parties, and is expressly made effective only for the purposes of this Agreement. The provisions of this section shall survive the expiration or termination of this Agreement.

## **PARK CITY MUNICIPAL CORPORATION SERVICE PROVIDER/PROFESSIONAL SERVICES AGREEMENT**

- B. No liability shall attach to the City by reason of entering into this Agreement except as expressly provided herein.

### **8. INSURANCE.**

The Service Provider shall procure and maintain for the duration of the Agreement, insurance against claims for injuries to persons or damage to property which may arise from or in connection with the performance of the work hereunder by the Service Provider, their agents, representatives, employees, or subcontractors. The Service Provider shall provide a Certificate of Insurance evidencing:

- A. General Liability insurance written on an occurrence basis with limits no less than One Million Dollars (\$1,000,000) per occurrence and Three Million Dollars (\$3,000,000) aggregate for personal injury, bodily injury and property damage.

The Service Provider shall increase the limits of such insurance to at least the amount of the Limitation of Judgments described in Section 63G-7-604 of the Governmental Immunity Act of Utah, as calculated by the state risk manager every two years and stated in Utah Admin. Code R37-4-3.

- B. Automobile Liability insurance with a combined single limit of not less than Two Million Dollars (\$2,000,000) each accident for bodily injury, death of any person, and property damage arising out of the ownership, maintenance, and use of owned, hired, and non-owned motor vehicles. This policy must not contain any exclusion or limitation with respect to loading or unloading of a covered vehicle.
- C. Professional Liability (Errors and Omissions) insurance (if applicable) with annual limits no less than One Million Dollars (\$1,000,000) per occurrence. Service Provider agrees to continue to procure and maintain professional liability insurance coverage meeting these requirements for the applicable period of statutory limitation of claims (or statute of repose, if applicable) after the project completion or termination of this Agreement.

If written on a claims-made basis, the Service Provider warrants that the retroactive date applicable to coverage precedes the effective date of this agreement; and that continuous coverage will be maintained for an extended reporting period endorsement (tail coverage) will be purchased for a period of at least three (3) years beginning from the time that work under this agreement is complete.

- D. Workers Compensation insurance and Employers Liability coverage with Workers Compensation limits complying with statutory requirements and Employer's Liability Insurance limits of at least One Million Dollars

## **PARK CITY MUNICIPAL CORPORATION SERVICE PROVIDER/PROFESSIONAL SERVICES AGREEMENT**

(\$1,000,000) each accident, One Million Dollars (\$1,000,000) for bodily injury by accident, and One Million Dollars (\$1,000,000) each employee for injury by disease.

- E. Park City Municipal Corporation, its officers, officials, employees, and volunteers are to be covered as additional insureds on general liability and auto liability insurance policies, with respect to work performed by or on behalf of the Service Provider including materials, parts, or equipment furnished in connection with such work or operations and automobiles owned, leased, hired, or borrowed by or on behalf of the Service Provider and a copy of the endorsement naming the City as an additional insured shall be attached to the Certificate of Insurance.
- F. Should any of the above-described policies be cancelled before the expiration date thereof, Service Provider shall deliver notice to the City within thirty (30) days of cancellation. The City reserves the right to request certified copies of any required policies.
- G. The Service Provider's insurance shall contain a clause stating that coverage shall apply separately to each insured against whom claim is made or suit is brought, except with respect to the limits of the insurer's liability.
- H. For any claims related to this Agreement, the Service Provider's insurance coverage shall be primary insurance coverage with respect to Park City Municipal Corporation, its officers, officials, employees, and volunteers. Any insurance or self-insurance maintained by Park City Municipal Corporation, its officers, officials, employees, or volunteers shall be excess of the Service Provider's insurance and shall not contribute with it.

### **9. TREATMENT OF ASSETS.**

Title to all property furnished by the City shall remain in the name of the City and the City shall become the owner of the work product and other documents, if any, prepared by the Service Provider pursuant to this Agreement (contingent on City's performance hereunder).

### **10. COMPLIANCE WITH LAWS AND WARRANTIES.**

- A. The Service Provider, in the performance of this Agreement, shall comply with all applicable federal, state, and local laws and ordinances, including regulations for licensing, certification and operation of facilities, programs and accreditation, and licensing of individuals, and any other standards or criteria as described in this Agreement to assure quality of services.
- B. Unless otherwise exempt, the Service Provider is required to have a valid Park City business license.

## **PARK CITY MUNICIPAL CORPORATION SERVICE PROVIDER/PROFESSIONAL SERVICES AGREEMENT**

- C. The Service Provider specifically agrees to pay any applicable fees or charges which may be due on account of this Agreement.
- D. If this Agreement is entered into for the physical performance of services within Utah, the Service Provider shall register and participate in E-Verify or an equivalent program. The Service Provider agrees to verify employment eligibility through E-Verify, or an equivalent program, for each new employee that is employed within Utah, unless exempted by Utah Code § 63G-12-302.
- E. Service Provider shall be solely responsible to the City for the quality of all services performed by its employees or sub-contractors under this Agreement. Service Provider hereby warrants that the services performed by its employees or sub-contractors will be performed substantially in conformance with the standard of care observed by similarly situated companies providing services under similar conditions.

### **11. NONDISCRIMINATION.**

Any Service Provider that enters into an agreement for goods or services with Park City Municipal Corporation or any of its boards, agencies, or departments shall:

- A. Implement an employment nondiscrimination policy prohibiting discrimination in hiring, discharging, promoting or demoting, matters of compensation, or any other employment- related decision or benefit against a person otherwise qualified, because of actual or perceived race; color; sex; pregnancy, childbirth, or pregnancy-related conditions; age, if the individual is 40 years of age or older; religion; national origin; disability; sexual orientation; gender identity; genetic information; or military status.
- B. In the performance of this Agreement, Service Provider shall not discriminate on account of actual or perceived race; color; sex; pregnancy, childbirth, or pregnancy-related conditions; age, if the individual is 40 years of age or older; religion; national origin; disability; sexual orientation; gender identity; genetic information; or military status.

## **PARK CITY MUNICIPAL CORPORATION SERVICE PROVIDER/PROFESSIONAL SERVICES AGREEMENT**

- C. Incorporate the foregoing provisions in all subcontracts or assignments hereunder and take such actions as may be required to ensure full compliance with the provisions of this policy.

### **12. ASSIGNMENTS/SUBCONTRACTING.**

- A. The Service Provider shall not assign its performance under this Agreement or any portion of this Agreement without the written consent of the City, and it is further agreed that said consent must be sought in writing by the Service Provider not less than thirty (30) days prior to the date of any proposed assignment. The City reserves the right to reject without cause any such assignment. Any assignment made without the prior express written consent of the City, as required by this paragraph, shall be deemed null and void.
- B. Any work or services assigned hereunder shall be subject to each provision of this Agreement and proper bidding procedures where applicable as set forth in local, state or federal statutes, ordinance and guidelines.
- C. Any technical/professional service subcontract not listed in this Agreement, must have express advance approval by the City.
- D. Each subcontractor that physically performs services within Utah shall submit an affidavit to the Service Provider stating that the subcontractor has used E-Verify, or an equivalent program to verify the employment status of each new employee, unless exempted by Utah Code § 63G-12-302.

### **13. CHANGES.**

Either party may request changes to the scope of services and performance to be provided hereunder, however, no change or addition to this Agreement shall be valid or binding upon either party unless such change or addition be in writing and signed by both Parties. Such amendments shall be attached to and made part of this Agreement.

### **14. PROHIBITED INTEREST, NO THIRD PARTY RIGHTS AND NO GRATUITY TO CITY EMPLOYEES.**

- A. No member, officer, or employee of the City shall have any interest, direct or indirect, in this Agreement or the proceeds thereof.
- B. Nothing herein is intended to confer rights of any kind in any third party.
- C. No City employee who has procurement decision making authority and is engaged in the procurement process, or the process of administering a



## **PARK CITY MUNICIPAL CORPORATION SERVICE PROVIDER/PROFESSIONAL SERVICES AGREEMENT**

contract, may knowingly receive anything of value including but not limited to gifts, meals, lodging or travel from anyone that is seeking or has a contract with the City.

### **15. MODIFICATIONS TO TASKS AND MISCELLANEOUS PROVISIONS.**

- A. All work proposed by the Service Provider is based on current government ordinances and fees in effect as of the date of this Agreement.
- B. Any changes to current government ordinances and fees which affect the scope or cost of the services proposed may be billed as an “extra” pursuant to Paragraph 3(C), or deleted from the scope, at the option of the City.
- C. The City shall make provision for access to the property and/or project and adjacent properties, if necessary, for performing the services herein.

### **16. TERMINATION.**

- A. Either party may terminate this Agreement, in whole or in part, at any time, by at least thirty (30) days' written notice to the other party. The Service Provider shall be paid its costs, including contract close-out costs, and profit on work performed up to the time of termination. The Service Provider shall promptly submit a termination claim to the City. If the Service Provider has any property in its possession belonging to the City, the Service Provider will account for the same, and dispose of it in a manner directed by the City.
- B. If the Service Provider fails to perform in the manner called for in this Agreement, or if the Service Provider fails to comply with any other provisions of the Agreement and fails to correct such noncompliance within three (3) days' written notice thereof, the City may immediately terminate this Agreement for cause. Termination shall be affected by serving a notice of termination on the Service Provider setting forth the manner in which the Service Provider is in default. The Service Provider will only be paid for services performed in accordance with the manner of performance set forth in this Agreement.

### **17. NOTICE.**

Notice provided for in this Agreement shall be sent by certified mail to the addresses designated for the Parties below. Notice is effective upon the date it was sent, except that a notice of termination pursuant to Paragraph 16 is effective upon receipt. All reference to “days” in this Agreement shall mean calendar days.

## **PARK CITY MUNICIPAL CORPORATION SERVICE PROVIDER/PROFESSIONAL SERVICES AGREEMENT**

### **18. ATTORNEYS FEES AND COSTS.**

If any legal proceeding is brought for the enforcement of this Agreement, or because of a dispute, breach, default, or misrepresentation in connection with any of the provisions of this Agreement, the prevailing party shall be entitled to recover from the other party, in addition to any other relief to which such party may be entitled, reasonable attorney's fees and other costs incurred in connection with that action or proceeding.

### **19. JURISDICTION AND VENUE.**

- A. This Agreement has been and shall be construed as having been made and delivered within the State of Utah and it is agreed by each party hereto that this Agreement shall be governed by the laws of the State of Utah, both as to interpretation and performance.
- B. Any action of law, suit in equity, or judicial proceeding for the enforcement of this Agreement, or any provisions thereof, shall be instituted and maintained only in any of the courts of competent jurisdiction in Summit County, Utah.

### **20. SEVERABILITY AND NON-WAIVER.**

- A. If, for any reason, any part, term, or provision of this Agreement is held by a court of the United States to be illegal, void or unenforceable, the validity of the remaining provisions shall not be affected, and the rights and obligations of the Parties shall be construed and enforced as if the Agreement did not contain the particular provision held to be invalid.
- B. If it should appear that any provision hereof is in conflict with any statutory provision of the State of Utah, said provision which may conflict therewith shall be deemed inoperative and null and void insofar as it may be in conflict therewith, and shall be deemed modified to conform in such statutory provisions.
- C. It is agreed by the Parties that the forgiveness of the non-performance of any provision of this Agreement does not constitute a subsequent waiver of the provisions of this Agreement. No waiver shall be effective unless it is in writing and signed by an authorized representative of the waiving party.

## **PARK CITY MUNICIPAL CORPORATION SERVICE PROVIDER/PROFESSIONAL SERVICES AGREEMENT**

### **21. ENTIRE AGREEMENT.**

The Parties agree that this Agreement is the complete expression of the terms hereto and any oral representations or understandings not incorporated herein are excluded. Further, any modification of this Agreement shall be in writing and signed by both Parties. Failure to comply with any of the provisions stated herein shall constitute material breach of contract and cause for termination. Both Parties recognize time is of the essence in the performance of the provisions of this Agreement.

### **22. COUNTERPARTS.**

This Agreement may be executed in counterparts, each of which will be deemed an original and all of which together will constitute one and the same instrument.

### **23. ELECTRONIC SIGNATURES.**

Each party agrees that the signatures of the parties included in this Agreement, whether affixed on an original document manually and later electronically transmitted or whether affixed by an electronic signature through an electronic signature system such as DocuSign, are intended to authenticate this writing and to create a legal and enforceable agreement between the parties hereto.

# PARK CITY MUNICIPAL CORPORATION SERVICE PROVIDER/PROFESSIONAL SERVICES AGREEMENT

IN WITNESS WHEREOF the Parties hereto have caused this Agreement to be executed the day and year first hereinabove written.

**PARK CITY MUNICIPAL CORPORATION**, a  
Utah municipal corporation  
445 Marsac Avenue  
Post Office Box 1480  
Park City, UT 84060-1480

DocuSigned by:  
*Matt Dias*  
\_\_\_\_\_  
Matt Dias, City Manager

Attest:

DocuSigned by:  
*[Signature]*   
\_\_\_\_\_  
City Recorder's Office

Approved as to form:

DocuSigned by:  
*Margaret Plane*  
\_\_\_\_\_  
City Attorney's Office

**VISIBILITY SIGN COMPANY, LLC**, a Utah  
limited liability company  
2255 S. 5370 W.  
City, State, Zip: West Valley City, Utah 84120

47-3505127

Tax ID#: \_\_\_\_\_

DocuSigned by:

*Aaron Maravilla*

Signature AF02C6CB266346F...

Aaron Maravilla

Printed name

President

Title

THE CITY REQUIRES THE SERVICE PROVIDER TO COMPLETE EITHER THE NOTARY BLOCK OR THE UNSWORN DECLARATION, WHICH ARE BELOW.

STATE OF UTAH            )  
  ) ss.  
COUNTY OF SUMMIT    )

On this \_\_\_\_ day of \_\_\_\_\_, 2023, personally appeared before me \_\_\_\_\_, whose identity is personally known to me/or proved to me on the basis of satisfactory evidence and who by me duly sworn/affirmed, did say that he/she is the \_\_\_\_\_ (*title or office*) of \_\_\_\_\_, a Utah limited liability company, by authority of its Operating Agreement/Member Resolution, and acknowledged that he/she signed it voluntarily for its stated purpose as \_\_\_\_\_ (title) for \_\_\_\_\_, a Utah limited liability company.

\_\_\_\_\_  
Notary Public

I declare under criminal penalty under the law of Utah that the foregoing is true and correct. Signed on the 21 day of September, 2023 at Utah, Salt Lake County (insert State and County here).

Printed name Aaron Maravilla

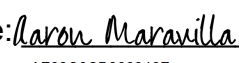
Signature:   
DocuSigned by:  
AF62C6CB266346F...

**EXHIBIT "A"**

**SCOPE OF SERVICES**



**EXHIBIT “B”**

**PAYMENT SCHEDULE FOR “EXTRA” WORK**

Any “Extra” Work shall be mutually agreed upon in advance in writing by the parties.

Template Updated 5-2020

Professional Service Agreement (Standard)

## **EXHIBIT "A"**

### **EMPOWERMENT UTILITY PRINTER BOX SCOPE OF SERVICES**

Service Provider will install wraps on 42 utility boxes throughout Park City according to the Access Agreement signed between the City and Rocky Mountain Power. This includes printing and installing vinyl graphics on multiple utility boxes. The list of locations and the Access Agreement are attached to this work scope.

The City will provide artwork to the Service Provider, who will provide an initial mock-up and production file setup. The service provider will provide time for the City and Rocky Mountain Power to review and provide any needed edits.

The Service Provider will conduct rust repair and cleaning of each box before the wraps are applied. Additionally, each utility box will be measured for accuracy, there are three box sizes. The average box size with tops is 132.3 sq. ft. for an average of 5,292 total average sq. ft. Wraps will include four sides and a top of each box.

A 3M-certified team will perform the installation. Service Provider will install each wrap on the selected boxes. Service Provider estimates for each box it will take 60 to 90 minutes. Estimated time and travel to install wraps is 110 hours.

City will be responsible for any permitting needs.

The total cost of the project will not exceed \$47,800.00.

#### **Estimated Timeline:**

Week of September 18: Service Provider receives artwork and begin mock-ups for City.

Week of September 25: Utility Boxes rust repair and wiped clean.

Week of October 2: Installation – forecast of 8 boxes installed per day.

Week of October 30: All work complete

## Exhibit A – Utility Box Locations &amp; Measurements

**Utility Box Locations & Measurements**

Attached is a list of Utility Boxes for the project. 37 project locations have been identified, and up to an additional 3 locations may be added. Manufacture and City Measurements are included. Selected Service Providers should also physically measure the selected locations before printing to verify exact measurements. Please consult the map that is also attached to this exhibit.

Location	Manufacturer Drawing#	City Measurements (inches)		
		Width	Height	Depth
1. Quinn's Junction fields	1	67	44 1/4	60 7/8
2. Round Valley Way (Peace House)				
3. Round Valley Way (Clinic)				
4. Round Valley Way (Hospital)				
5. HWY 248 (Ingress)				
6. Hwy 248 (School District Building)				
7. Hwy 248 (School District Building #2)				
8. Arts District				
9. Prospector				
10. Park Meadows (Monitor Drive Across from Wellsfargo)				
11. Monitor Drive				
12. Park Meadows (Little Kate)				
13. Park Meadows (Holiday Ranch Loop /Creekside Water Treatment Plant				
14. Versante / Peaks Hotel				
15. Police Station				
16. Police Station #2				
17. Golf Course (Thaynes Canyon Drive)				
18. Park City Hotel/ Golf Course				
19. Three Kings				
20. 1700 Payday Condos				
21. Three Kings #2				
22. Golf Course #2				
23. Park Ave & 15 <sup>th</sup> Street				
24. Park Ave & 9 <sup>th</sup> Street				
25. Park Ave & 9 <sup>th</sup> Street #2				
26. Poison Creek Trail – Near Ontario Mine Mural				
27. Park City Mountain Resort (PCMR First Time Lot)				
28. Park City Mountain Resort (Lowell/Manor)				
29. Wheaton Way #1				
30. Wheaton Way #2				
31. Wheaton Way #3				
32. Deer Valley Drive #1				
33. Deer Valley Drive #2				
34. Deer Valley Drive #3				
35. Deer Valley Drive #4				
36. Deer Valley Drive #5				
37. Deer Valley Drive #6				
38. Deer Valley Drive #7				
39. Deer Valley Drive #8				
40. Deer Valley Drive #9				
41. Sidewinder Drive (Prospector)				
42. 224 White Barn				

### Exhibit A – Utility Box Locations & Measurements

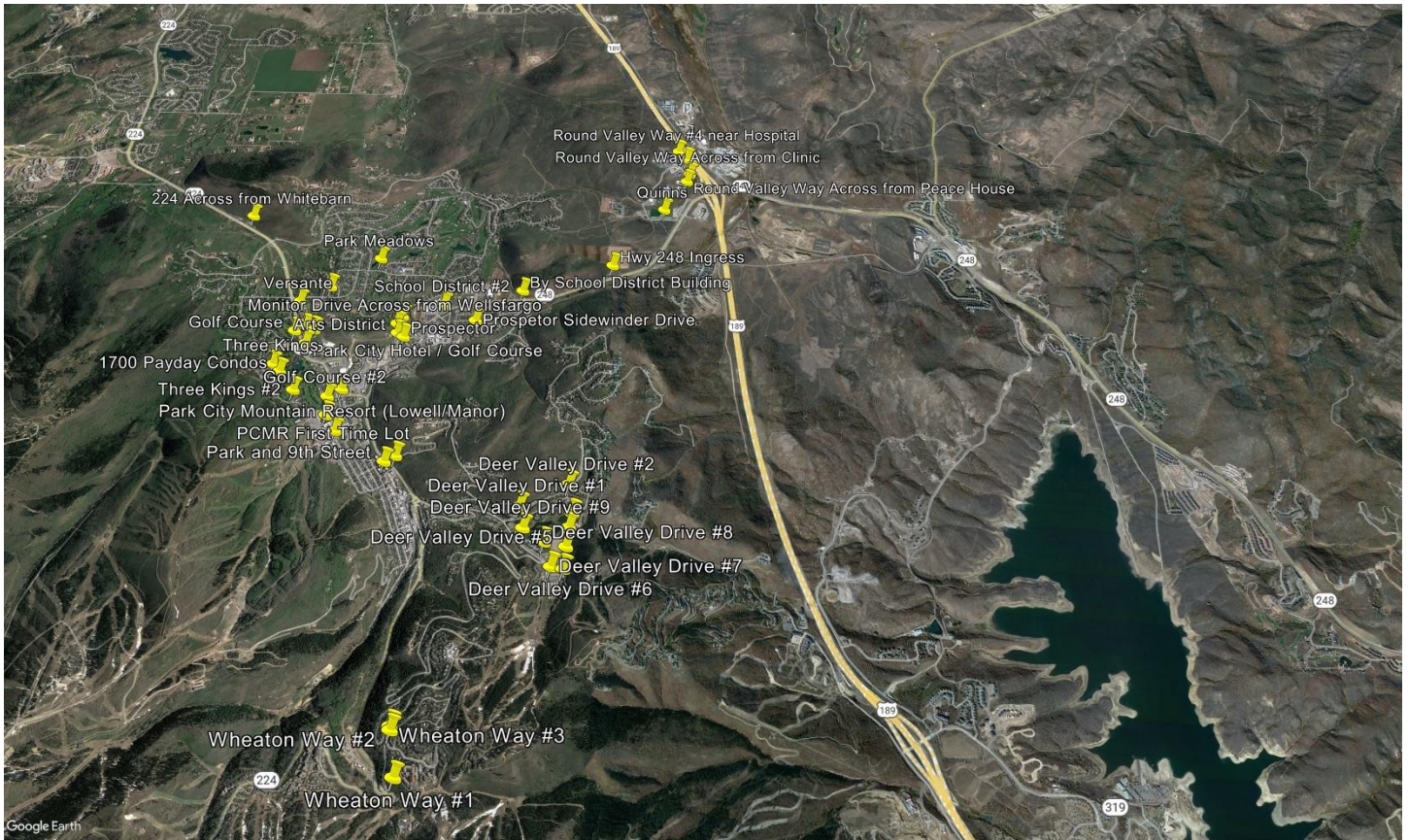

#1

S&C Manual PMH Pad-Mounted Gear

**Model PMH-9**  
14.4 kV and 25 kV Nominal

Dimensions in inches (mm)

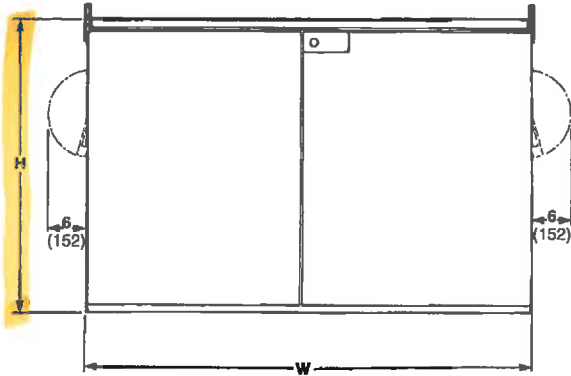

FRONT VIEW

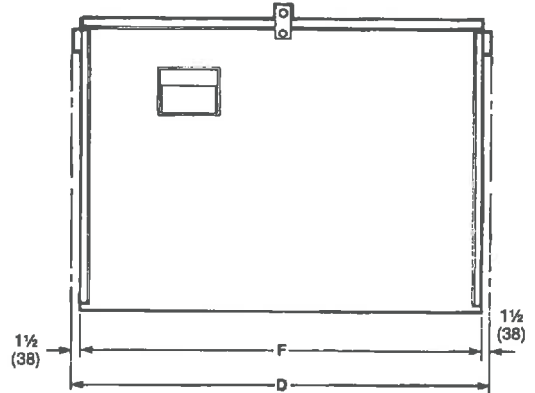

SIDE VIEW

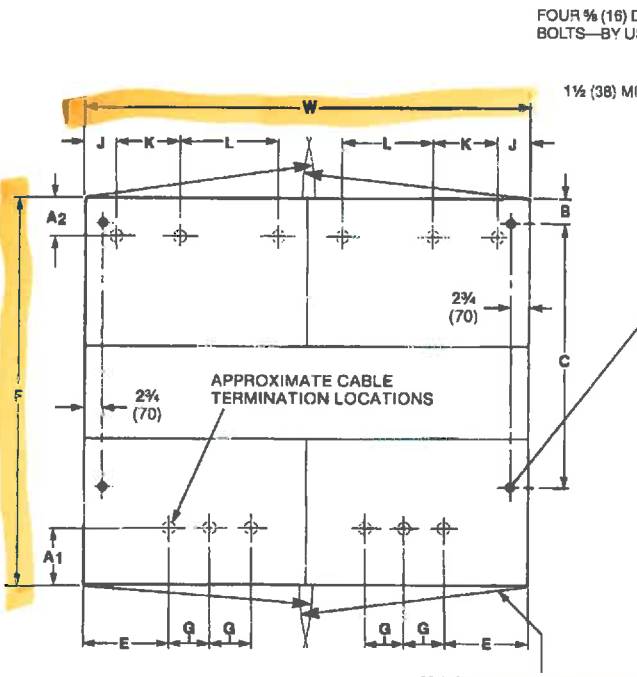

ANCHOR BOLT PLAN

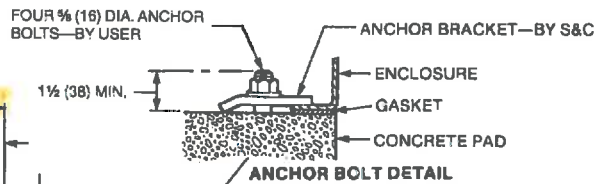

ANCHOR BOLT DETAIL

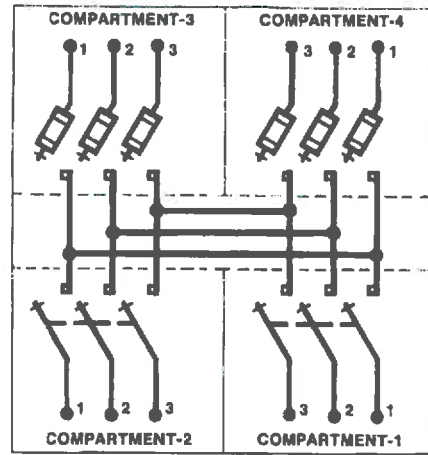

CONNECTION DIAGRAM

kV, Nominal	A <sub>1</sub> ◆	A <sub>2</sub>	B	C	D	E	F	G	H	J	K	L	M	W
14.4	9 7/8 (251)	7 (178)	5 1/2 (130)	40 (1016)	63 3/4 (1619)	12 7/8 (327)	80 3/4 (1543)	6 (152)	44 (1118)	4 3/4 (121)	9 3/4 (248)	14 3/4 (375)	34 (864)	67 (1702)
25	14 1/8 (359)	11 1/4 (286)	7 1/2 (181)	62 1/2 (1588)	79 3/4 (2026)	13 3/4 (349)	76 3/4 (1949)	7 1/2 (191)	55 (1397)	6 (152)	12 1/2 (318)	16 1/2 (419)	41 1/2 (1054)	82 (2083)

◆ When Catalog Number Suffix "-M1," "-U2," or "-U3" is specified, cable-termination locations will be slightly affected. Consult your nearest S&C Sales Office for details.

S&C Manual PME Pad-Mounted Gear

Model PME-11

Dimensions in inches (mm)

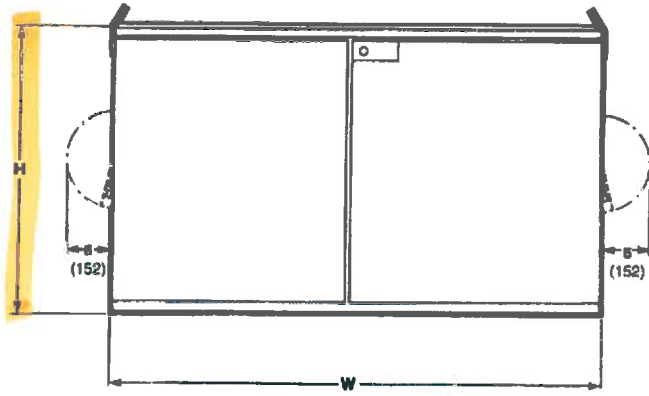

FRONT VIEW

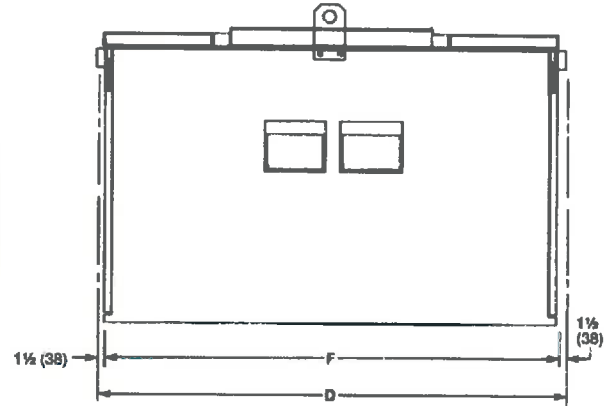

SIDE VIEW

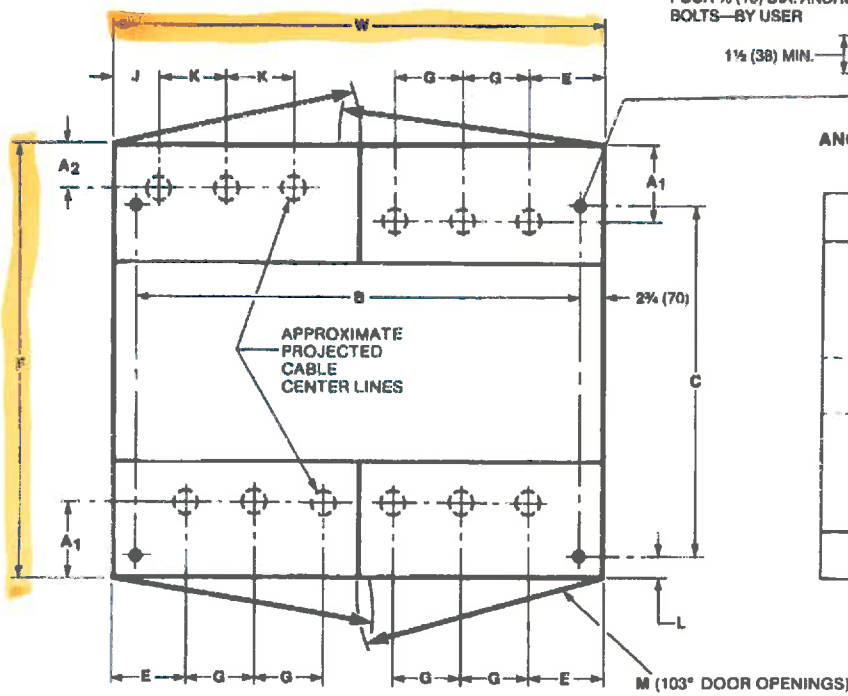

ANCHOR BOLT PLAN

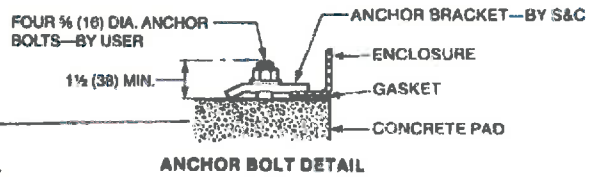

ANCHOR BOLT DETAIL

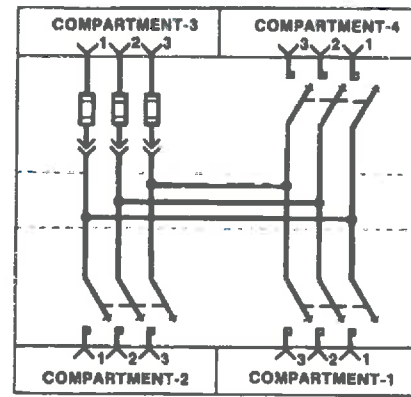

CONNECTION DIAGRAM

kV, Nominal	A <sub>1</sub> ◆	A <sub>2</sub> ◆	B	C	D	E	F	G	H	J	K	L	M	W
14.4	14½ (368)	7 (178)	69½ (1765)	55½ (1765)	75¾ (1924)	12¾ (314)	72¾ (1848)	8¼ (210)	45.5 (1156)	5¾ (137)	10¾ (273)	8¾ (219)	38 (965)	75 (1905)
25	18½ (470)	8¾ (206)	78½ (1994)	58½ (1468)	91¼ (2318)	12¾ (327)	88¾ (2242)	8¼ (210)	51.5 (1308)	6 (152)	12 (305)	14¾ (378)	42½ (1080)	84 (2134)

◆ Projected cable center lines are applicable for PME models with cable installed in a cable pit. For cable installed in conduit, refer to pages 22 and 23.

#3

S&C Manual PME Pad-Mounted Gear

Model PME-9

Dimensions in inches (mm)

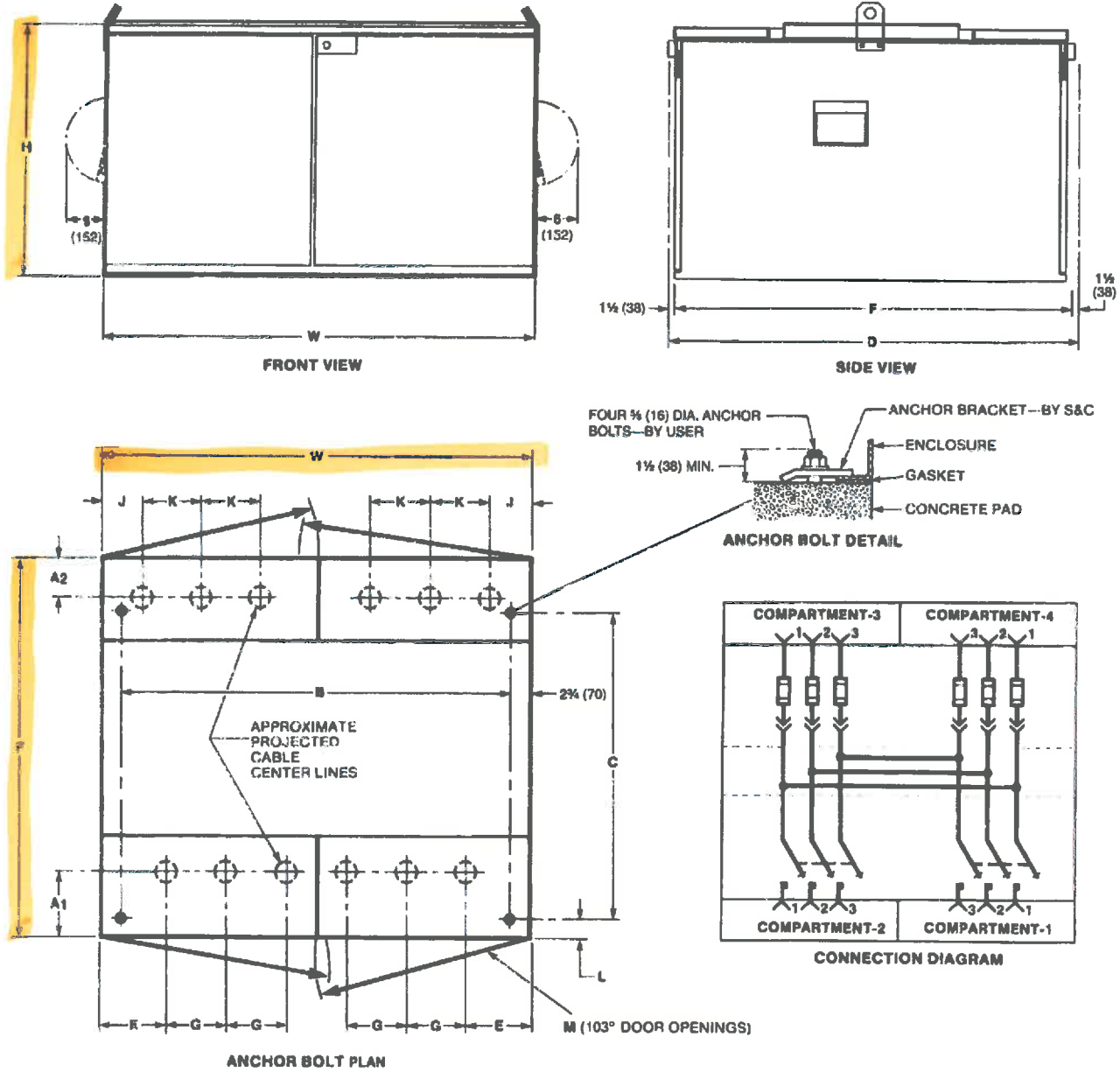

kV, Nominal	A <sub>1</sub> ◆	A <sub>2</sub> ◆	B	C	D	E	F	G	H	J	K	L	M	W
14.4	14½ (368)	7 (178)	69½ (1765)	49½ (1257)	69¾ (1772)	12¾ (314)	66¾ (1695)	8¼ (210)	45.5 (1156)	5¾ (137)	10¾ (273)	8¾ (219)	38 (965)	75 (1905)
25	18½ (470)	8¾ (206)	78½ (1994)	52 (1321)	84¾ (2153)	12¾ (327)	81¾ (2076)	8¼ (210)	51.5 (1308)	6 (152)	12 (305)	14¾ (378)	42½ (1080)	84 (2134)

◆ Projected cable center lines are applicable for PME models with cable installed in a cable pit. For cable installed in conduit, refer to pages 22 and 23.

## REVOCABLE RIGHT OF ACCESS AGREEMENT

This REVOCABLE RIGHT OF ACCESS AGREEMENT (“Agreement”), dated April 17, 2023, is by and between **PACIFICORP, an Oregon corporation, d/b/a ROCKY MOUNTAIN POWER** (“Licensor”) and **PARK CITY MUNICIPAL CORPORATION**, a Utah municipal corporation (Licensee”).

### RECITALS

A. Licensor owns, operates, and maintains transmission and distribution assets in Licensee’s public places pursuant to a five-year electric utility franchise granted by Licensee to Licensor on January 1, 2023; and

B. Licensee desires and Licensor is willing to allow Licensee to implement a community art program to allow local artists to decorate certain pad mounted equipment owned by Licensor and located in Park City, Utah; and

C. Licensor has agreed to grant a temporary, non-exclusive and revocable license to Licensee solely for the purpose of permitting Licensee and its designated artists (the “Licensee Parties”) to decorate designated pad mounted equipment located in Park City, Utah (the “Project”).

### AGREEMENT

NOW THEREFORE, for good and valuable consideration, the receipt and sufficiency of which are hereby acknowledged, the parties agree as follows:

1. Right of Entry. Licensor hereby grants to Licensee Parties the right to paint or decorate pad mounted equipment designated by Licensor, subject to the following conditions:

a. Licensee Parties shall strictly comply with any instructions, directions or restrictions promulgated by Licensor;

b. Any artwork on Licensor’s pad mounted equipment is limited to the area between the ground line and eight feet (8’) above the ground line;

c. Any tag, label, lock, or warning sign affixed to Licensor’s pad mounted equipment shall remain intact, unaltered, and not decorated or otherwise covered;

d. Any ladder or stool used to apply the artwork will be free standing and not allowed to contact Licensor’s pad mounted equipment;

e. Licensee Parties shall not modify, move, or remove any part of Licensor’s pad mounted equipment, or any equipment attached thereto;



f. Licenser may change, modify and/or replace any pad mounted equipment as required or in its sole discretion;

g. Licenser will designate the number and location of pad mounted equipment to be used by Licensee Parties for the Project in its sole discretion, after discussing the Project with Licensee.

h. Licensee will be responsible for removing, or will reimburse Licenser for the costs of removing, any unauthorized graffiti, painting or other modification to Licenser's pad mounted equipment that Licensee or Licensee Parties create.

i. Licenser may revoke this Agreement with written notice to the Licensee no less than five (5) business days before revocation, at its sole discretion.

j. Licenser will be given the opportunity to approve the decorations prior to implementation as part of the Project.

k. Licensee shall give Licenser ten (10) business days' advance written notice of the Licensee Parties' intent to begin the Project. Such notice shall set forth the exact date and approximate time when the activities are proposed to occur. In the event the proposed date and time are unacceptable to Licenser, Licensee agrees to cooperate with Licenser in scheduling a substitute date and time.

2. Compliance with Law. Licensee shall secure, at its expense, any and all necessary permits and shall comply with all applicable federal, state and local laws, regulation and enactments applicable to this Agreement. Licensee Parties shall perform and stage the Project so as to ensure the safety of: (a) Licensee Parties; (b) any and all Licenser operations conducted in the area; (c) surrounding property owners; and (d) the public in general.

3. Indemnification. Licensee, for itself, its successors, agents, contractors and employees, hereby jointly and severally releases, relinquishes and discharges Licenser and agrees to and does hereby agree to jointly and severally indemnify, defend and hold harmless, Licenser and its officers, directors, employees, representatives, agents, attorneys and consultants ("Indemnitees") from and against any and all actions, claims, losses, costs, damages, expenses, penalties, assessments, injury, liability and judgments, orders, governmental directives, penalties, administration and judicial proceedings and other liabilities of any kind to the extent caused by, arising out of or occurring in connection with the Project and/or this Agreement (including, without limitation reasonable attorney's fees and expert witness fees) caused by any Licensee Parties' performance of activities in connection with this Agreement or the Project, including, without limitation, claims for personal injuries, including disease and death, property loss or damage or injuries to others relating to the activities under this Agreement. The foregoing release and indemnity shall survive the termination of this Agreement. Nothing in this provision shall be construed as a waiver of any immunity, protection, or rights granted to Licensee under the Governmental Immunity Act of Utah, Utah Code § 63G-7-101, et seq.

4. Insurance. Licensee shall maintain in full force during the entire term of the Agreement commercial general liability insurance in an amount of not less than Two Million

Dollars (\$2,000.000) per occurrence insuring against claims for bodily injury, death or property damage occurring as a result of the Project. Licensee may elect to assume such liabilities and risk of loss through deductibles and/or a qualified self-insurance program.

5. Notices. Any notice, communication, report or demand required or desired to be given under this Agreement shall be in writing delivered at the addresses shown below or at such other address as the respective parties may from time to time designate by like notice. Each such notice shall be effective upon being delivered.

To Licensor:           Andy Badger  
                              Regional Business Manager  
                              P.O Box 39  
                              Midvale, Utah 84047

With a copy to:       Rocky Mountain Power  
                              Office of General Counsel  
                              1407 West North Temple, Suite 320  
                              Salt Lake City, UT 84116

To Licensee Parties:  Jenny Diersen  
                              Park City Public Art Advisory Board Liaison  
                              Park City Municipal Corporation  
                              P.O. Box 1480  
                              Park City, Utah 84060

6. Termination of Agreement. If any of the Licensee Parties fail to observe the conditions of this Agreement after notice from Licensor and fail to cure within five (5) business days, this Agreement may be terminated by Licensor without further notice; provided, however, that in the event of a material violation of this Agreement by any of the Licensee Parties, this Agreement may be terminated immediately without providing the Licensee Parties an opportunity to cure the default.

7. Miscellaneous.

a. Captions. The captions of the sections of this Agreement are for convenience only and shall not be considered or referred to in resolving questions of interpretation and construction.

b. Governing Law. This Agreement shall be construed, interpreted and applied in accordance with the internal laws of the State of Utah, without regard to principles of conflicts of law. Jurisdiction and venue for litigation arising from this Agreement shall be in Salt Lake County.

c. Integration; Amendment. This Agreement may not be altered, modified, or amended unless by an instrument in writing duly executed by each of the parties then bound by this Agreement. This Agreement constitutes all of the agreements and understandings of the

parties concerning the subject matter contained herein and supersedes all prior oral or written agreements or understandings.

d. Severability. If any one or more of the provisions of this Agreement shall for any reason be held invalid, illegal or unenforceable in any respect, that invalidity, illegality or unenforceability shall not affect any other provision herein and this Agreement shall be construed as if the invalid, illegal or unenforceable provision had never been included, provided, however, in no event shall either party be deprived of a material consideration by operation of this provision.

e. Attorneys' Fees and Expert Witness Fees. In the event any party hereto brings an action or proceeding for a declaration of the rights of the parties under this Agreement, an interpretation of this Agreement, for injunctive relief, or for an alleged breach or default of, or any other action arising out of, this Agreement or the transactions contemplated hereby, the prevailing party in any such action shall be entitled to an award of reasonable attorneys' fees and costs and expert witness fees incurred in such action or proceeding, without regard to any rule of court or schedule of such fees maintained by the court, in addition to any other damages or relief awarded, regardless of whether such action proceeds to final judgment.

f. Binding Effect. The Licensee Parties shall not have the right to assign this Agreement without the prior written consent of Licensor, which may be withheld in Licensor's sole and absolute discretion. Subject to the foregoing, this Agreement shall be binding upon and inure to the benefit of the parties hereto and their respective heirs, legal representatives, tenants, lenders, and successors and assigns.

g. Warranty of Authorized Signatories. Each of the signatories hereto warrants and represents that he or she is competent and authorized to enter into this Agreement on behalf of the party for whom he or she purports to sign.

h. Reservation of Rights. Each of the rights of the parties set forth in the individual sections of this Agreement are in addition to, and not exclusive of, the rights of such party, at law, in equity or otherwise. No damages or remedies available to a party at law, in equity or otherwise, shall be deemed or construed to be limited by or under the terms of this Agreement, other than as provided in Section 8.

i. Non-Waiver. The failure of Licensor to insist on strict performance of the terms hereunder will not be deemed as a waiver of any rights or remedies that Licensor may have for any subsequent breach, default, or non-performance and Licensor's right to insist on strict performance of this Agreement. No waiver is valid unless set forth in writing signed by the waiving party.

8. Jury Waiver. To the fullest extent permitted by law, Licensor and Licensee Parties waive any right they may have to a trial by jury in respect of litigation directly or indirectly arising out of, under, or in connection with this Agreement. Each party further waives any right to consolidate any action in which a jury trial has been waived with any other action in which a jury trial cannot be or has not been waived.

IN WITNESS WHEREOF, the parties hereto have executed this Agreement effective as of the date and year first above written.

**Licensor:**

PacifiCorp, an Oregon corporation, d/b/a Rocky Mountain Power

By:   
Kelly Jepsen

Its: Distribution Manager

Dated: 5/3/2023

**Licensee:**

Park City Municipal Corporation, a Utah municipal corporation

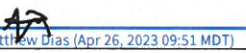
By:   
Matthew Dias (Apr 26, 2023 09:51 MDT)  
Matt Dias

Its: City Manager

Dated: \_\_\_\_\_



# CERTIFICATE OF LIABILITY INSURANCE

DATE (MM/DD/YYYY)

7/5/2023

**THIS CERTIFICATE IS ISSUED AS A MATTER OF INFORMATION ONLY AND CONFERS NO RIGHTS UPON THE CERTIFICATE HOLDER. THIS CERTIFICATE DOES NOT AFFIRMATIVELY OR NEGATIVELY AMEND, EXTEND OR ALTER THE COVERAGE AFFORDED BY THE POLICIES BELOW. THIS CERTIFICATE OF INSURANCE DOES NOT CONSTITUTE A CONTRACT BETWEEN THE ISSUING INSURER(S), AUTHORIZED REPRESENTATIVE OR PRODUCER, AND THE CERTIFICATE HOLDER.**

**IMPORTANT: If the certificate holder is an ADDITIONAL INSURED, the policy(ies) must have ADDITIONAL INSURED provisions or be endorsed. If SUBROGATION IS WAIVED, subject to the terms and conditions of the policy, certain policies may require an endorsement. A statement on this certificate does not confer rights to the certificate holder in lieu of such endorsement(s).**

<b>PRODUCER</b> Brisk Advisors 5005 S. 900 E. STE 200  SALT LAKE CITY UT 84117	<b>CONTACT NAME:</b> Carolyn Crossley <b>PHONE (A/C, No, Ext):</b> (801) 266-6800		<b>FAX (A/C, No):</b>
	<b>E-MAIL ADDRESS:</b> carolyn@briskadvisors.com		
<b>INSURED</b> Visibility Sign Company LLC 2255 S 5370 W Ste 100  West Valley City UT 84120-1330	<b>INSURER(S) AFFORDING COVERAGE</b>		<b>NAIC #</b>
	<b>INSURER A:</b> CINCINNATI INS CO		10677
	<b>INSURER B:</b> WCF Mutual Insurance Company		10033
	<b>INSURER C:</b>		
	<b>INSURER D:</b>		
	<b>INSURER E:</b>		

**APPROVED**

**COVERAGES CERTIFICATE NUMBER: REVISION NUMBER:**

THIS IS TO CERTIFY THAT THE POLICIES OF INSURANCE LISTED BELOW HAVE BEEN ISSUED TO THE INSURED NAMED ABOVE FOR THE POLICY PERIOD INDICATED. NOTWITHSTANDING ANY REQUIREMENT, TERM OR CONDITION OF ANY CONTRACT OR OTHER DOCUMENT WITH RESPECT TO WHICH THIS CERTIFICATE MAY BE ISSUED OR MAY PERTAIN, THE INSURANCE AFFORDED BY THE POLICIES DESCRIBED HEREIN IS SUBJECT TO ALL THE TERMS, EXCLUSIONS AND CONDITIONS OF SUCH POLICIES. LIMITS SHOWN MAY HAVE BEEN REDUCED BY PAID CLAIMS.

INSR LTR	TYPE OF INSURANCE	ADDL INSD	SUBR WVD	POLICY NUMBER	POLICY EFF (MM/DD/YYYY)	POLICY EXP (MM/DD/YYYY)	LIMITS	
A	<input checked="" type="checkbox"/> <b>COMMERCIAL GENERAL LIABILITY</b> <input type="checkbox"/> CLAIMS-MADE <input checked="" type="checkbox"/> OCCUR GEN'L AGGREGATE LIMIT APPLIES PER: <input checked="" type="checkbox"/> POLICY <input type="checkbox"/> PRO-JECT <input type="checkbox"/> LOC OTHER:			EPP 0335512	06/25/2023	06/25/2024	EACH OCCURRENCE	\$ 1,000,000
		Y					DAMAGE TO RENTED PREMISES (Ea occurrence)	\$ 500,000
							MED EXP (Any one person)	\$ 10,000
							PERSONAL & ADV INJURY	\$ 1,000,000
							GENERAL AGGREGATE	\$ 2,000,000
							PRODUCTS - COMP/OP AGG	\$ 2,000,000
								\$
A	<b>AUTOMOBILE LIABILITY</b> <input type="checkbox"/> ANY AUTO <input type="checkbox"/> OWNED AUTOS ONLY <input type="checkbox"/> SCHEDULED AUTOS <input checked="" type="checkbox"/> HIRED AUTOS ONLY <input checked="" type="checkbox"/> NON-OWNED AUTOS ONLY			EPP 0335512	06/25/2023	06/25/2024	COMBINED SINGLE LIMIT (Ea accident)	\$ 1,000,000
		Y					BODILY INJURY (Per person)	\$
							BODILY INJURY (Per accident)	\$
							PROPERTY DAMAGE (Per accident)	\$
								\$
A	<input checked="" type="checkbox"/> <b>UMBRELLA LIAB</b> <input checked="" type="checkbox"/> OCCUR <input type="checkbox"/> EXCESS LIAB <input type="checkbox"/> CLAIMS-MADE DED RETENTION \$			EPP 0335512	06/25/2023	06/25/2024	EACH OCCURRENCE	\$ 1,000,000
							AGGREGATE	\$ 1,000,000
								\$
B	<b>WORKERS COMPENSATION AND EMPLOYERS' LIABILITY</b> ANY PROPRIETOR/PARTNER/EXECUTIVE OFFICER/MEMBER EXCLUDED? (Mandatory in NH) If yes, describe under DESCRIPTION OF OPERATIONS below	Y/N	N/A	4042703	01/01/2023	01/01/2024	<input checked="" type="checkbox"/> PER STATUTE <input type="checkbox"/> OTH-ER E.L. EACH ACCIDENT	\$ 1,000,000
							E.L. DISEASE - EA EMPLOYEE	\$ 1,000,000
							E.L. DISEASE - POLICY LIMIT	\$ 1,000,000

**DESCRIPTION OF OPERATIONS / LOCATIONS / VEHICLES (ACORD 101, Additional Remarks Schedule, may be attached if more space is required)**

Certificate Holder is Additional Insured with respects to the General Liability per form GA 233 09 17, and Auto Liability per form AA 4004 03 06. Coverage is applicable when required by written contract and is subject to policy terms and conditions.

<b>CERTIFICATE HOLDER</b>  Park City Municipal  445 Marsac Ave  Park City UT 84060	<b>CANCELLATION</b>  SHOULD ANY OF THE ABOVE DESCRIBED POLICIES BE CANCELLED BEFORE THE EXPIRATION DATE THEREOF, NOTICE WILL BE DELIVERED IN ACCORDANCE WITH THE POLICY PROVISIONS.
	AUTHORIZED REPRESENTATIVE  <i>Carolyn Crossley</i>